

# Presentation to NHS – HE Forum

## NHSScotland Update

Edinburgh 20<sup>th</sup> September 2010

Ron MacDonald

NISGTelecom

# Topics

- Video Conferencing
- Beyond N3
- Future of NHSmail

# Video Conferencing in the NHS

- Supporting Telehealth - To improve the quality of services for patients. Local access to services.
- Professional education and development
- To improve access to Clinical expertise in rural areas,
- Produce Efficiency savings by reducing travel

But Video services seen as unreliable and difficult to use

# VC in NHSScotland c 2009

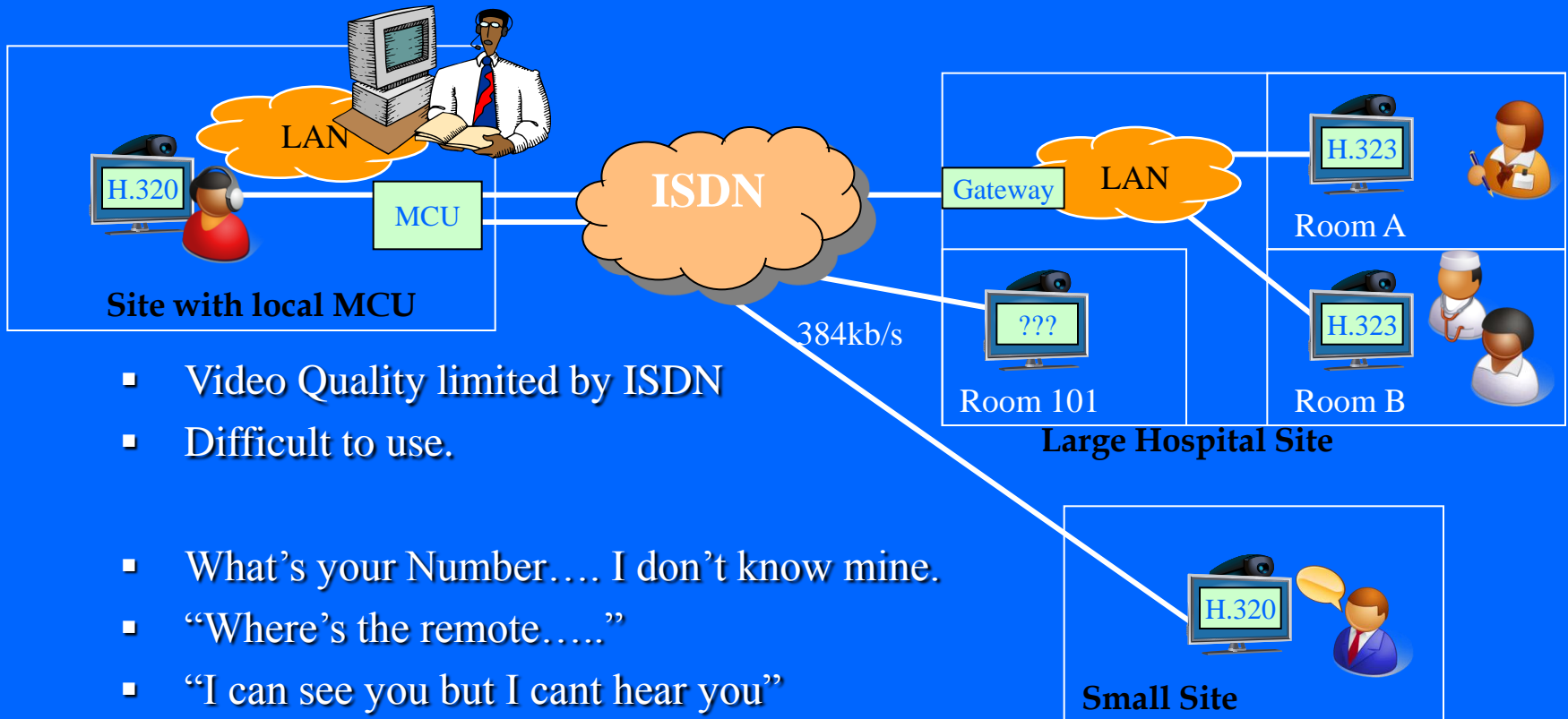

- Video Quality limited by ISDN
- Difficult to use.
- What's your Number.... I don't know mine.
- "Where's the remote....."
- "I can see you but I cant hear you"
- "I've never been able to dial them before so lets just continue without them"

Multiple Instances, no Management system, no directory

# National Video Conferencing Pilot

- Makes use of existing NHSBoard equipment.
- National Directory and Local conference booking
  - Automatically populated from NHSBoard systems
  - Available on line
  - Making it easier to book and start a conference
- Conversion from ISDN to IP
  - National Video Gatekeeper Service
  - Routes Board A to Board B Video over N3.
  - Improving the video quality.
- Trial with NHSGrampian. Highland, Tayside, Western Isles, Orkney and Shetland

**Local NHSBoard Support continues.**

# Pilot - What would be provided

- A National Gatekeeper and Management System
  - Enables National Directory and migration to N3.
  - Licences for around 300 devices
  - 1 year support of above equipment
  - Installation and testing
- Developing standards
- Not in scope:
  - National MCU (or Bridging service)
  - Gateway (IP- ISDN)
  - Licences for Boards out-with trial

# VC Estate Analysis - 2009

	No of Devices	No of Sites	Sites > 10Mb/s	Devices on sites >10Mb/s
North of Scot	342	95	23.2%	47.1%
Non NOS	251	104	41.3%	72.5%
Total	593	199	32.7%	57.8%

A further estimated 200 Devices have been bought.

# Agreed Gatekeeper Architecture

- Hierarchy structure
- One National (NHSScotland) Gatekeeper
- Optional NHSboard Gatekeepers
- NHSBoards can register direct to National Gatekeeper
- Appropriate number plan to facilitate.



# Gatekeeper Hierarchy – Pilot

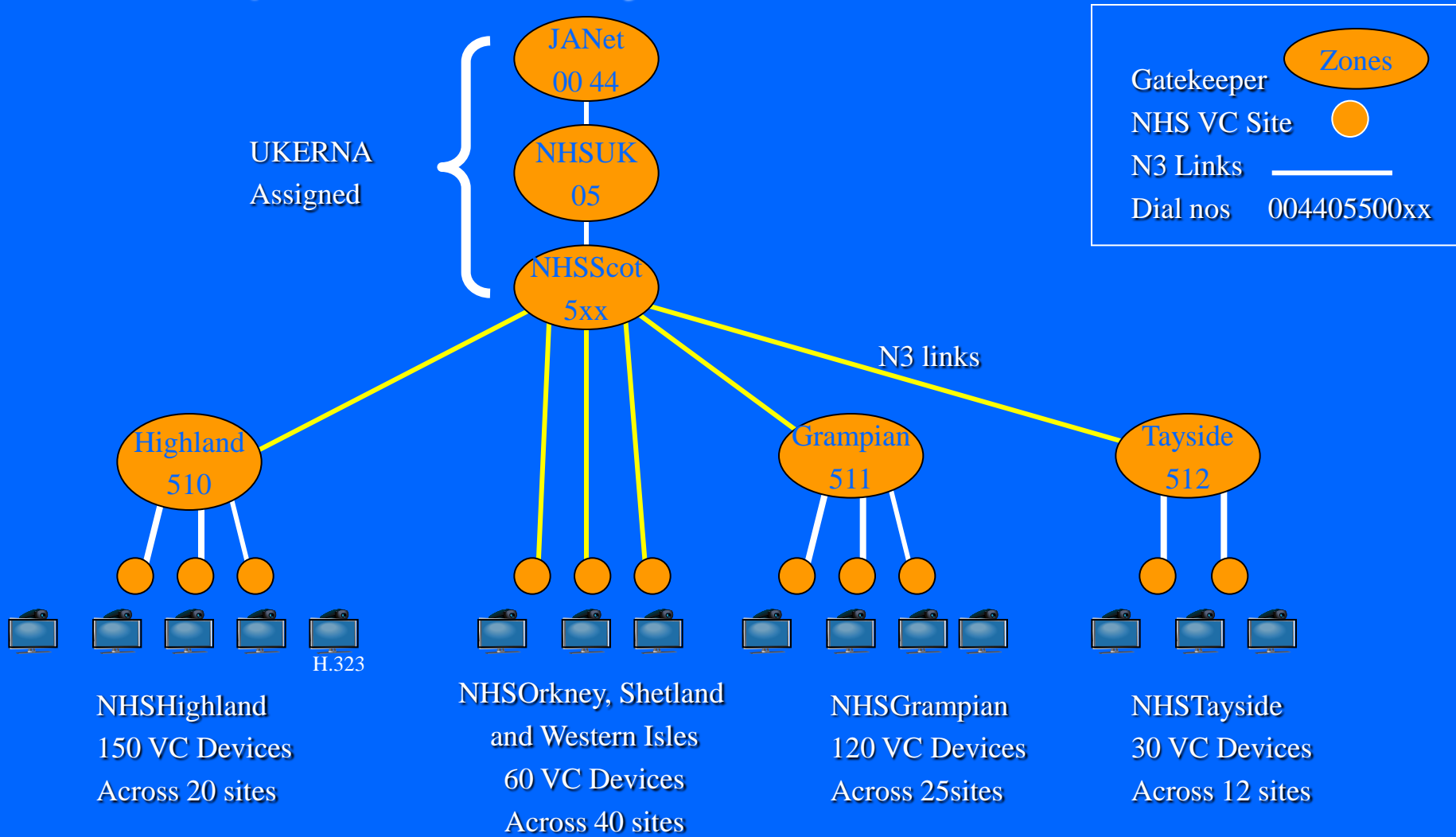

Each VC device will have a six digit extension

# VC Progress

- National Directory and Gatekeeper System live.
  - 5<sup>th</sup> November 2011
  - 457 Endpoints registered at September 11
- Standards agreed and implemented across entire pilot estate
  - Dial plan based on JANet numbering scheme
  - Directory naming convention.
- Remote access capability added in July 2011
  - Enables staff to work from home or on the move.
- North of Scotland Pilot considered complete August 11
- Pressure to extend to Non NoS Boards
  - Infrastructure upgraded to support 1000 end points
  - Support extended to June 2012
  - Over 80 Non NoS Boards end points on Directory
  - 75% of NHS Boards have converted to N3

# VC Progress

Health Board	Devices Jan10	Adopted dial plan		On Directory	
		Code	Numbers	Code	Numbers
Ayr & Arran	24	513		NHSAA	
Borders	1	514	?	NHSBOR	
Dumfries & Galloway	25	515		NHSDG	
Fife	11	516	?	NHSFIF	
Forth Valley	6	517	?	NHSFV	
Grampian	114	511	111	NHSGRA	111
Greater Glasgow & Clyde	44	518	21	NHSGGC	21
Highland	141	510	189	NHSHIG	189
Lanarkshire	9	519		NHSLAN	
Lothian	52	520	?	NHSLOT	1
Orkney	31	521	9	NHSORK	9
Shetland	18	522	6	NHSSHE	6
Tayside	26	512	51	NHSTAY	51
Western Isles	12	523	1	NHSWI	1
NHS24	3	524	1	NHS24	1
NSS	30	525	40	NHSNSS	40
Scottish Ambulance Service	9	526		NHSSAS	
Golden Jubilee Nat Hosp	3	527	?	NHSGJ	
Quality Improvement Service	9	528		NHSQIS	
National Education for Scotland	17	529	28	NHSNES	28
State Hospital	0	530	?	NHSSH	
Health Scotland	0	521	?	NHSHS	
<b>TOTAL</b>	<b>593</b>		<b>???</b>		<b>457</b>

**Not started**

# Top Level Phone Book

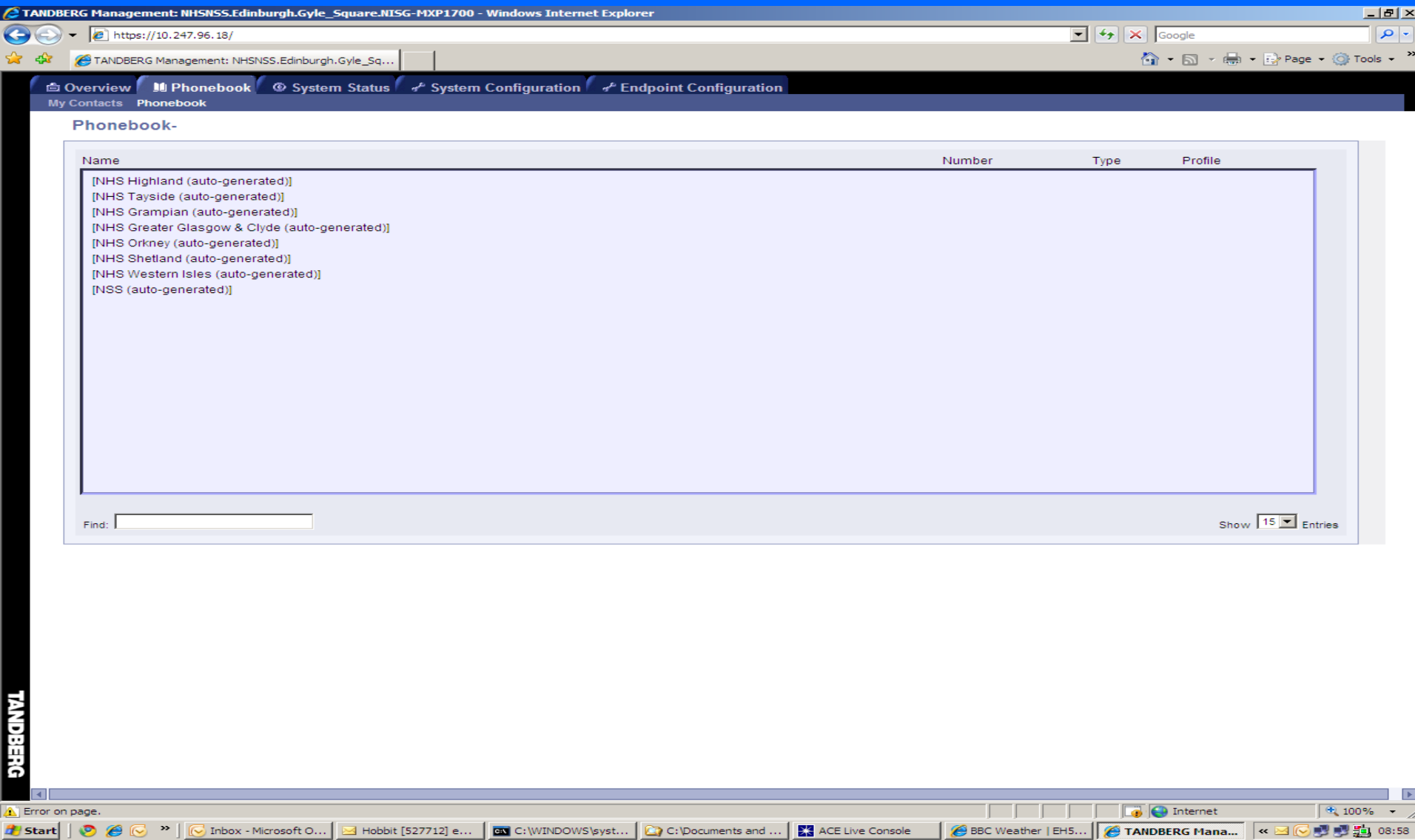

TANDBERG Management: NHSNSS.Edinburgh.Gyle\_Square.NISG-MXP1700 - Windows Internet Explorer

https://10.247.96.18/

TANDBERG Management: NHSNSS.Edinburgh.Gyle\_Sq...

Overview Phonebook System Status System Configuration Endpoint Configuration

My Contacts Phonebook

### Phonebook-

Name	Number	Type	Profile
[NHS Highland (auto-generated)]			
[NHS Tayside (auto-generated)]			
[NHS Grampian (auto-generated)]			
[NHS Greater Glasgow & Clyde (auto-generated)]			
[NHS Orkney (auto-generated)]			
[NHS Shetland (auto-generated)]			
[NHS Western Isles (auto-generated)]			
[NSS (auto-generated)]			

Find:

Show 15 Entries

Start | Error on page. | Internet | 100%

Inbox - Microsoft O... | Hobbit [527712] e... | C:\WINDOWS\syst... | C:\Documents and ... | ACE Live Console | BBC Weather | EH5... | TANDBERG Mana... | 08:58

# Individual Health Board (Highland)



TANDBERG Management: NHSNSS.Edinburgh.Gyle\_Square.NISG-MXP1700 - Windows Internet Explorer

https://10.247.96.18/

TANDBERG Management: NHSNSS.Edinburgh.Gyle\_Sq...

Overview Phonebook System Status System Configuration Endpoint Configuration

My Contacts Phonebook

### Phonebook- NHS Highland (auto-generated)

Name	Number	Type	Profile
NHSH.Avenmore.Rainven (H323)	510667938	Auto	H323
NHSH.Bowmore.Islay_Hospital.Audiology_Room (H323)	510572307	Auto	H323
NHSH.Bowmore.Islay_Hospital.Education_Room (H323)	510605021	Auto	H323
NHSH.Broadford.MMH.Meeting_Room (H323)	510667984	Auto	H323
NHSH.Campbeltown.Dental.Tutorial_Room (H323)	510605006	Auto	H323
NHSH.Campbeltown.Open_Learning_Centre (H323)	510605023	Auto	H323
NHSH.Campbeltown.Seminar_Room (H323)	510572308	Auto	H323
NHSH.Dingwall.Larachan_House.Meeting_Room (H323)	510855662	Auto	H323
NHSH.Dingwall.Larachan_House.Mid_CHP_General_Mgr (	510855669	Auto	H323
NHSH.Dingwall.Larachan_House.Small_Meeting_Rm (H32	510667996	Auto	H323
NHSH.Dingwall.RMH.OoH_Service_Desktop (H323)	510855663	Auto	H323
NHSH.Dunaros.DCH (H323)	510605020	Auto	H323
NHSH.Dunoon.CCH.Meeting_Room_A01 (H323)	510605022	Auto	H323
NHSH.Dunoon.CCH.Meeting_Room_A02 (H323)	510572306	Auto	H323
NHSH.Dunoon.Locality_Manager (H323)	510605026	Auto	H323
NHSH.Dunoon.Long_Term_Conditions_Manager (H323)	510605008	Auto	H323
NHSH.Durness.Health_Centre (H323)	510667912	Auto	H323
NHSH.Easdale.GP (H323)	510572311	Auto	H323
NHSH.Fort_William.Belford_Hospital.Desktop (H323)	510708241	Auto	H323
NHSH.Fort_William.Belford_Hospital.Teaching_Room (	510708248	Auto	H323
NHSH.Fort_William.Belford_Hospital.Teledialysis (H	510708245	Auto	H323

Find:

Show  Entries

TANDBERG

Done

Start

Inbox - Microso...

Hobbit [527712...

C:\WINDOWS\s...

C:\Documents a...

ACE Live Console

BBC Weather | ...

TANDBERG Ma...

Microsoft Power...

Internet

100%

09:02

# Online Video Conferencing System Directories and Maps

# On Line Directory



- **Developed by NHS Highland**
- **Aim:**

**To produce an auto-updated online video conference system directory that is:**

- Easy to use
- Quick to access
- Bandwidth light

# On Line Directory

Currently only available within NHS Highland

## **NHS Scotland Online Video Conference Directory.**

### **Directory to view**

NHS Highland (auto-generated)



Select Directory

### **To search**

**Select directory.**

**Enter full or partial name and click on SEARCH**

Search



# On Line Directory

## Step 1: Select a Healthboard

### NHS Scotland Online Video Conference Directory.

#### Directory to view

NHS Highland (auto-generated) 
<b>NHS Highland (auto-generated)</b>
NHS Tayside (auto-generated)
All NHS (auto-generated data)
NHS Grampian (auto-generated)
NHS Greater Glasgow & Clyde (auto-generated)
NHS Orkney (auto-generated)
NHS Shetland (auto-generated)
NHS Western Isles (auto-generated)
NSS (auto-generated)

on SEARCH

# On Line Directory

## Shows all entries within a Healthboard

**NHS Scotland Online Video Conference Directory.**

**Directory to view**

**To search**

Select directory.

Enter full or partial name and click on **SEARCH**

System Name	ISDN	Internal	Contact
NHSH.Aviemore.Health_Centre	01463 667488	004405 510667488	Alan Bolt - 01479 810258
NHSH.Aviemore.Rathven	01463 667938	004405 510667938	
NHSH.Bowmore.Islay_Hospital.Audiology_Room	01631 572307	004405 510572307	
NHSH.Bowmore.Islay_Hospital.Education_Room	01546 605021	004405 510605021	
NHSH.Broadford.MMH.Meeting_Room	01463 667984	004405 510667984	
NHSH.Campbeltown.Locality_Manager	01586 605028	004405 510605028	
NHSH.Campbeltown.Open_Learning_Centre	01586 605023	004405 510605023	
NHSH.Campbeltown.Seminar_Room	01631 572308	004405 510572308	
NHSH.Dingwall.Larachan_House.Meeting_Room	01349 855662	004405 510855662	Donna Coyne - 01349 869221
NHSH.Dingwall.Larachan_House.Mid_CHP_General_Mgr	01349 855669	004405 510855669	Donna Coyne - 01349 869221
NHSH.Dunaros.DCH	01546 605020	004405 510605020	
NHSH.Dunoon.CCH.Meeting_Room_A01	01546 605022	004405 510605022	
NHSH.Dunoon.CCH.Meeting_Room_A02	01631 572306	004405 510572306	
NHSH.Dunoon.Locality_Manager	01436 605026	004405 510605026	
NHSH.Dunoon.Long_Term_Conditions_Manager	01436 605008	004405 510605008	
NHSH.Fort_William.Belford_Hospital.Desktop	01397 708241	004405 510708241	
NHSH.Fort_William.Belford_Hospital.Teaching_Room	01397 708248	004405 510708248	

# On Line Directory

## Step 2: Search for units at a location

**NHS Scotland Online Video Conference Directory.**

**Directory to view**

**To search**  
**Select directory.**  
**Enter full or partial name and click on SEARCH**

System Name	ISDN	Internal	Contact
NHSH.Inverness.Alder_House.Desktop	01463 663327	004405 510663327	
NHSH.Inverness.Alder_House.Meeting_Room	01463 663282	004405 510663282	

# On Line Directory

## Step 3: Search for a specific unit

**NHS Scotland Online Video Conference Directory.**

**Directory to view**

NHS Highland (auto-generated)

**To search**  
**Select directory.**  
**Enter full or partial name and click on SEARCH**

robinson

System Name	ISDN	Internal	Contact
NHSH.Inverness.Raigmore.eHealth.L_Robinson	01463 663299	004405 510663299	Lynn Robinson 01463 705209

# On Line Map

## Live interactive map using Bing Maps

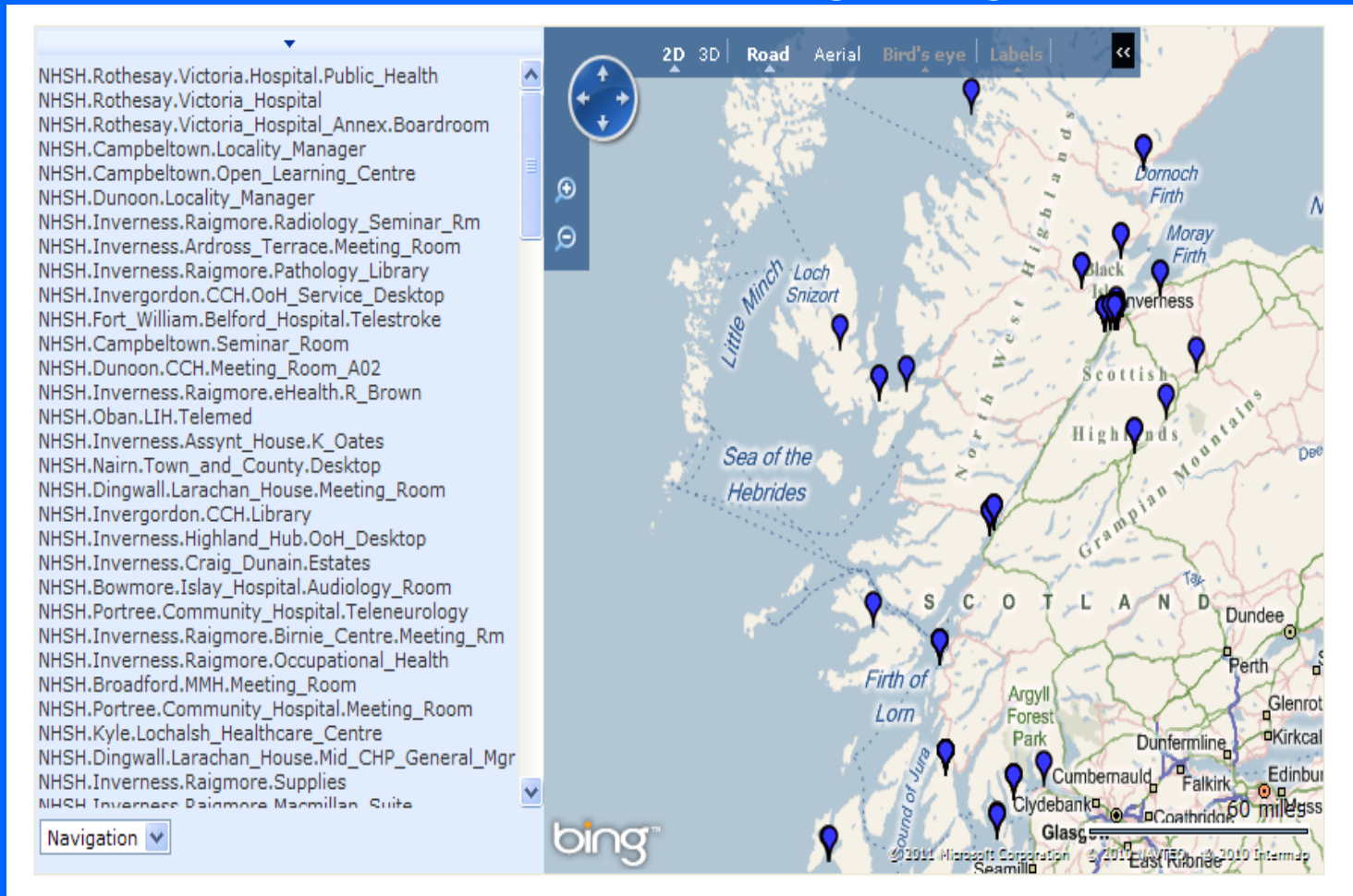

The screenshot displays a Bing Maps interface showing a map of Scotland with numerous blue location pins. On the left side, a list of NHS facility names is displayed, including:

- NHSH.Rothesay.Victoria.Hospital.Public\_Health
- NHSH.Rothesay.Victoria\_Hospital
- NHSH.Rothesay.Victoria\_Hospital\_Annex.Boardroom
- NHSH.Campbeltown.Locality\_Manager
- NHSH.Campbeltown.Open\_Learning\_Centre
- NHSH.Dunoon.Locality\_Manager
- NHSH.Inverness.Raigmore.Radiology\_Seminar\_Rm
- NHSH.Inverness.Ardrross\_Terrace.Meeting\_Room
- NHSH.Inverness.Raigmore.Pathology\_Library
- NHSH.Invergordon.CCH.OoH\_Service\_Desktop
- NHSH.Fort\_William.Belford\_Hospital.Telestroke
- NHSH.Campbeltown.Seminar\_Room
- NHSH.Dunoon.CCH.Meeting\_Room\_A02
- NHSH.Inverness.Raigmore.eHealth.R\_Brown
- NHSH.Oban.LIH.Telemed
- NHSH.Inverness.Assynt\_House.K\_Oates
- NHSH.Nairn.Town\_and\_County.Desktop
- NHSH.Dingwall.Larachan\_House.Meeting\_Room
- NHSH.Invergordon.CCH.Library
- NHSH.Inverness.Highland\_Hub.OoH\_Desktop
- NHSH.Inverness.Craig\_Dunain.Estates
- NHSH.Bowmore.Islay\_Hospital.Audiology\_Room
- NHSH.Portree.Community\_Hospital.Teleneurology
- NHSH.Inverness.Raigmore.Birnie\_Centre.Meeting\_Rm
- NHSH.Inverness.Raigmore.Occupational\_Health
- NHSH.Broadford.MMH.Meeting\_Room
- NHSH.Portree.Community\_Hospital.Meeting\_Room
- NHSH.Kyle.Lochalsh\_Healthcare\_Centre
- NHSH.Dingwall.Larachan\_House.Mid\_CHP\_General\_Mgr
- NHSH.Inverness.Raigmore.Supplies
- NHSH.Inverness.Raigmore.Macmillan\_Suite

The map interface includes navigation controls (2D, 3D, Road, Aerial, Bird's eye, Labels), a search bar, and a scale bar (60 miles). The map shows various Scottish locations such as Dornoch Firth, Moray Firth, Inverness, Black Isle, Scottish Highlands, Grampian Mountains, Sea of the Hebrides, Firth of Lorn, and Glasgow.

# On Line Map

## Live interactive information and status

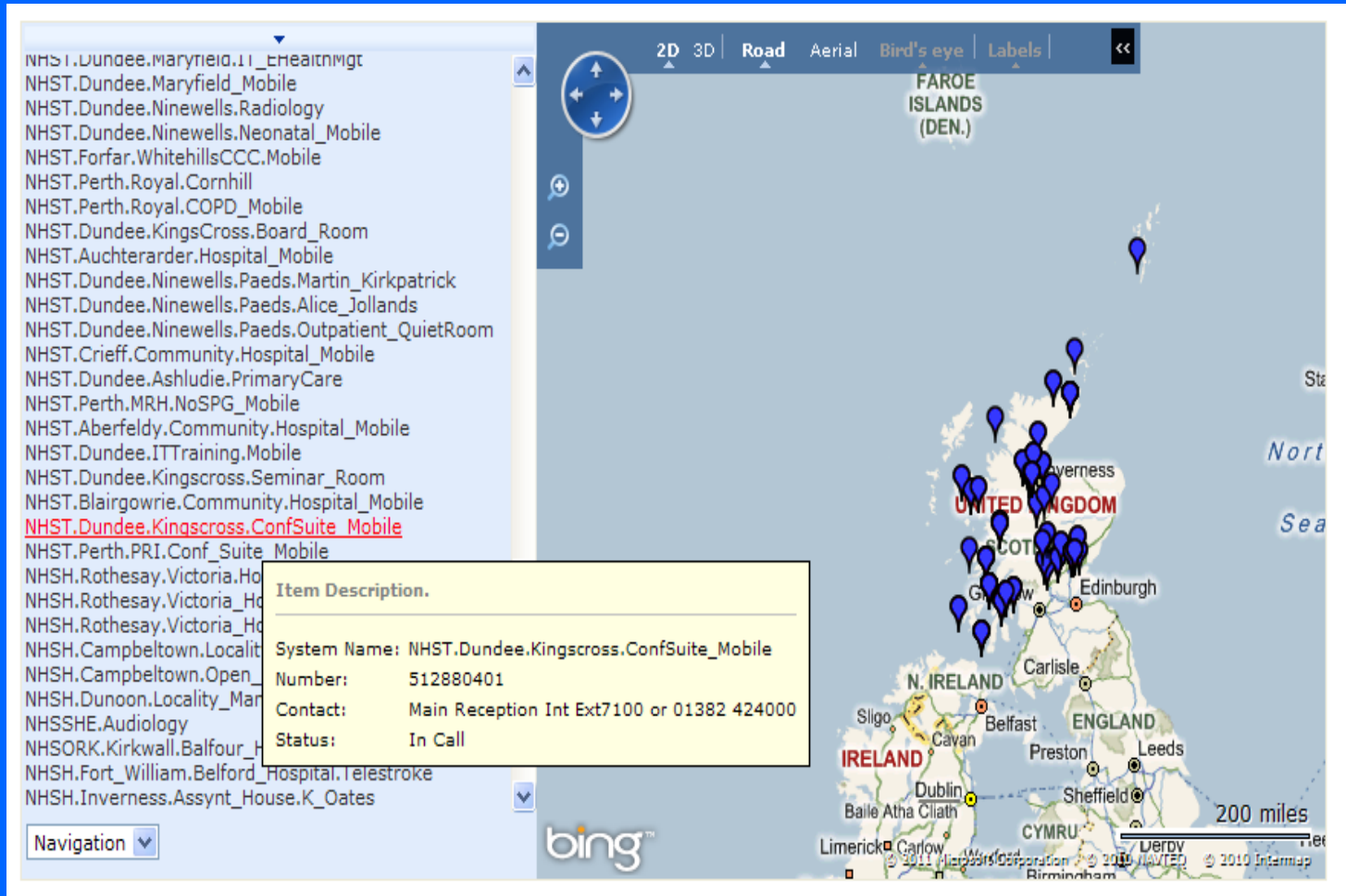

The screenshot shows a web-based map application. On the left, a list of NHS services is displayed, with one item highlighted in red. On the right, a map of the United Kingdom is shown with several blue location pins. A pop-up window provides details for the selected item.

**Item Description.**

System Name:	NHST.Dundee.Kingscross.ConfSuite_Mobile
Number:	512880401
Contact:	Main Reception Int Ext7100 or 01382 424000
Status:	In Call

The map interface includes navigation controls (2D, 3D, Road, Aerial, Bird's eye, Labels) and a scale bar (200 miles). The map shows the United Kingdom with various cities labeled, including Edinburgh, Glasgow, London, and Manchester.

# Some outstanding Issues

- Bandwidth Availability and affordability in rural areas
- End to end Video service support
  - Variable End User/end device support
    - Some NHSBoards have no dedicated support staff
  - Multi-conferencing management
    - No formal SLAs between NHSBoards.
    - No Business Continuity - no buddy arrangements
- Code of Connection
  - Agreement on need for standards. E.g. Minimum Bandwidth
- Absence of a Video services strategy for patients
- Connectivity via IP with JANet and other sectors.
- Room based – PC based Integration
  - Numerous PC based Collaborative tools being deployed

# What happens next?

- Dial plan implemented to the rest of Scotland.
  - Enough national gatekeeper licences
- Directory Management System extension require further procurement.
- ISDN to IP Central gateway.
- IP Connectivity with JANet and Scottish Government
  - Looking at a Guest process for IP and ISDN access.
- Support Video communications to Patients?
  - COPD rehab, Stroke, Decision support - using Movi
- Start Business Case
  - Workshop complete in June
  - Service, including room and conference support
  - Functionality, e.g. Integration with desktop video
  - Long list of Options by 20<sup>th</sup> October.



# Beyond N3

# Beyond N3 Background

- N3 Contract
  - Last orders – April 13
  - Last service – April 16
- Contract can be extended by a further year
  - However only England can make this decision
  - Creates uncertainty.
- Need to start planning now.

# PSN

- PSN (Public Sector Network)
- Network of Networks
- Multiple suppliers
- Common Security standards across public sector
  - Debate with NHS on standards ongoing
  - Concerns about security standards
- SG looking at a SPSN
  - Option for N3 replacement
  - Public Sector Network for Scotland
- Awaiting SG response to McClelland
  - Probably October before position is clear

**Meanwhile NHSScotland to look at life beyond N3**

# Beyond N3 Progress

- NHSBoard high level requirements workshops complete
- Report to e-Health leads
- Detailed Statement of Requirement
- Initial agreement in November
- Also SPSN starting
  - Information gathering
- Strategy to run with NHS only and SPSN for now but requirements need to be developed either option.

# Common issues and Concerns

	Key Risks & Issues	Comments
1	Service Continuity	Biggest concern. National and local applications will be around for 7 years. Need to start procurement in September
2	Transition Costs	Who Pays
3	Fragmentation across NHSScotland	Increase in Core and common network services cost, if we don't stick together.
4	Loss of aggregation	Potential Increase Core and common services costs if we divorce NHSEngland and don't get another partner.
5	Imposed standards from 3 <sup>rd</sup> parties	Need to take the lead. Cant sit back and let that happen. Existing standards well developed.
6	Sharing at local level	L.A's all different. Not at expense of sharing with NHS.
7	SPSN	What is it and when will it be available. Health should decide and influence.
8	Term of Contract	7 Years + extensions . Avoids future transition cost

# Common Requirement – from Regional

Item	Comments
Network Traffic trends	Will remain Local and national. Difficult to predict, use historical data from N3 and project forward.
Demand Drivers	Teleheath to Patients homes, Imaging, virtual desktop environment, inter Board video, portal inter regional and/or board, local PMS back-up, Sharing with LAs.
Internet Connectivity	Benefits of a single connection for NHSScotland provided access control and content delivery devolved locally
Remote Access	Need to allow local remote access solutions through and any future NHSScotland Internet arrangement.
Shared Services	Network must support complex traffic flows.
Voice & Video services	Not convinced that Voice or video services should be brought into a WAN contract. Network needs to support good quality Voice & Video.
Service Level requirements	Don't need such high SLAs for Pharmacists and Dentists. May go to Internet. Higher service levels for Hospitals.

# Recommendations

- A decision on NHS involvement in SPSN (Scottish Public Service Network) needs to be made by September or else N3 contract will need to be extended another year or start procurement.
- A detailed Statement of Requirement should be developed within the eHealth leads infrastructure group.

# NHSMail



# NHSmail

- Independent Consultants declare NHSmail good value
  - But concerns about licensing costs.
- Service ends in June 2013
  
- Business case process has started
  - Initial agreement October 2011
  - Looking at Cloud options

- *Any Questions?*